

VAS 6095 A / 1-22



Engine Support Bracket Base Minus

Owner's Manual





Chapter		Page
1.	Safety	
1.1	Information regarding this manual	4
1.2	Explanation of symbols	4
1.3	Markings	5
1.4	Scope of supply	5
1.5	Safety instructions	6
2.	Technical data	
2.1	Technical specifications	7
2.2	Technical data	7
2.3	Intended use	8
2.4	Basic principles for working with the engine support bracket	9
2.5	Regular inspection and maintenance	9
3.	Application	
3.1	Application	10
3.2	Completing the operation and storing the engine support bracket	11
4.	Service	
4.1	Troubleshooting	12
4.2	Warranty	13
4.3	Disposal	13
4.4	Declaration of Conformity	14

1.1 Information regarding this manual

State-of-the-art This engine support bracket represents state-of-the-art technology. To ensure functionality, it must be operated in a proper and safe manner.

Technical modifications In the interests of quality assurance, we reserve the unrestricted right to implement technical modifications arising from further developments in technology and product improvements without prior notice.

Reading owner's manual Before using the engine support bracket, read the manual carefully and comply with it.

Handling All handling necessary to ensure correct operation is described in the owner's manual. No methods of working other than those approved by the manufacturer may be practiced.

1.2 Explanation of symbols

In this owner's manual, some sections use internationally known warning symbols, warning notes and general instruction symbols. The individual symbols are explained below. Follow all instructions and safety rules.



Follow manual



Please note the following.



Arrow showing direction



Warning
General source of danger



Arrow to clarify compression



Turn clockwise



Warning
Hand could become trapped



For more information, see
section ...



Turn counterclockwise

XX Nm Use the specified torque

1.3 Designations



Markings on the support

A	Warning notice	F	Serial number / date of manufacture
B	Factory address	G	Note
C	CE mark	H	Manufacturer's identification
D	Dead weight	I	Part number
E	Max. rated load		



1.4 Scope of supply

1 x VAS 6095 A / 1-22 Engine support bracket



4x screws M12x1.5x35 10.9



4x washers ISO7090-13-St



1.5 Safety instructions



The engine support bracket is approved solely for the intended use designated by the manufacturer.



Ensure that the tool is only operated by trained personnel who are instructed in how to use it.



Use of the tool by personnel who have not undergone the requisite training and instruction is prohibited.



Make sure that the manual is accessible to operating personnel. Before operating this device for the first time, each operator must read this owner's manual carefully. It must always be available where the product is being used. In addition to the owner's manual, the binding provisions of the accident prevention regulations applicable at the place of use and the general, accepted rules for safety compliance and professional working must be observed.



Comply with the nameplate and labels on the device.



Risk of crushing and serious injury here!



Comply with the accident prevention regulations of the country in which the device is being used.



The tool, including labels, must be visually inspected before each use.



Never throw the tool or allow it to fall. Never misuse the tool or lend it to untrained personnel.



The safety instructions must be read and understood before any repair work is performed. Failure to read the instructions may result in serious bodily injury.



Alterations to the engine support bracket are not permitted.



The manufacturer bears no liability for any alterations or modifications made to the support or for any resulting personal injury.

Only the Base Minus engine may be lifted with the support.



When lifting and lowering the load, avoid bumping into obstacles.



Do not use the device to carry people and do not climb on the lifted load.



The stated nominal load of 70 kg (154.3 lbs) must not be exceeded.



Follow the Volkswagen AG repair manual.



References to repair manuals must always be taken into consideration.



Wear safety shoes and gloves.



2.1 Technical specifications

Model number	VAS 6095 A / 1-22
Weight	6.8 kg (14.9 lbs)
Max. rated load	70 kg (154.3 lbs)
Dimensions (W x H x D) in mm / in	176 x 330 x 125 (6.9 x 12.9 x 4.9 in)
Coefficient for the static test	2-fold (against deformation), 3-fold (against breakage)
Temperature	-20°C to +60°C (-4°F to 140°F)

2.2 Technical data

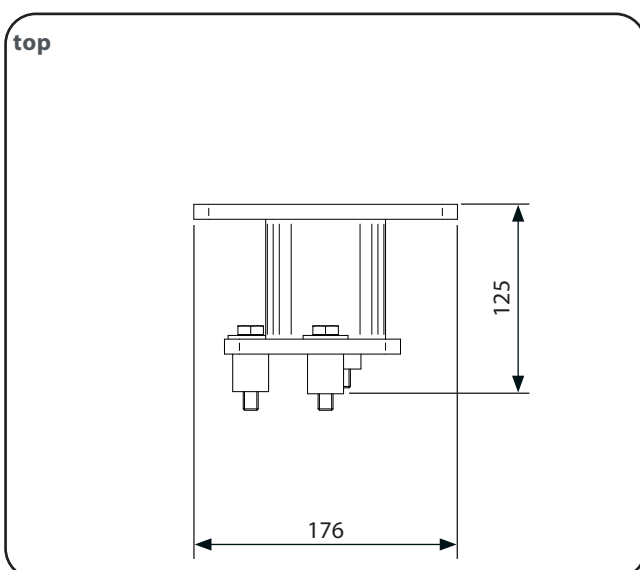
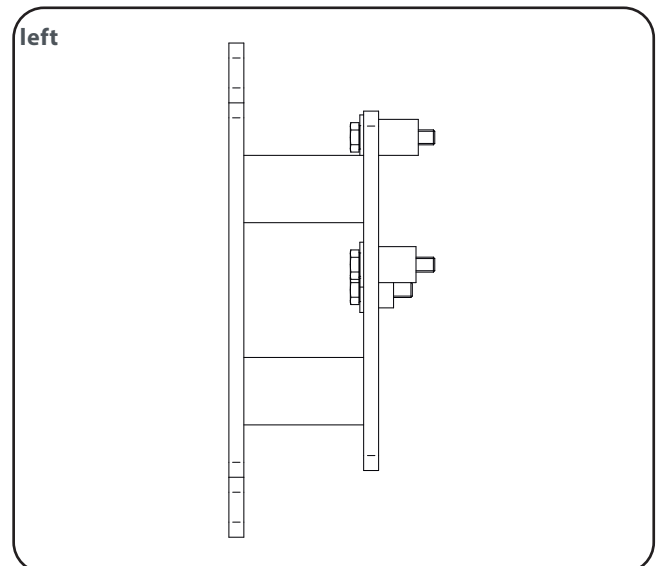
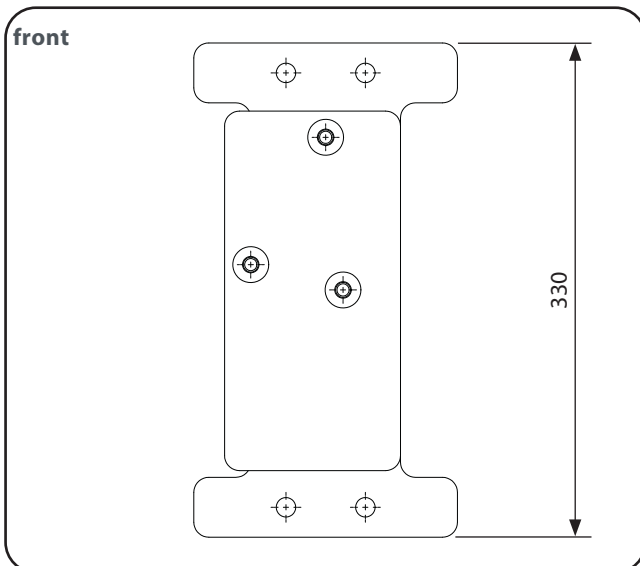

Engine support bracket

Width: 176 mm (6.9 in)
Height: 330 mm (12.9 in)
Depth: 125 mm (4.9 in)

2.3 Intended use

Intended use According to Volkswagen AG's specifications, the device is used exclusively to support a max. load of 70 kg (220.5 lbs) (Base Minus engine). Only use the device together with VW 309A and VAS 6095A.

Incorrect use The load-carrying capacity of 70 kg (220.5 lbs) indicated on the engine support bracket is the maximum rated load that may be lifted by the engine support bracket. The engine support bracket is not to be used for any other purpose.



Do not lift, lower or rotate the engine support bracket while people are in the danger zone of the load.



Standing beneath the load while it is being lifted, lowered or rotated is not permitted.

Before initiating lifting, lowering or rotating, the operator must first ensure that the engine support bracket is properly secured.



Do not loosen the engine support bracket screws while it is loaded.

When installing the engine support bracket, make sure that the operator is not endangered by the tool itself or by the universal stand.

The load must be lifted / lowered / rotated slowly and carefully.

Consult the manufacturer before using the support in certain (e.g. high humidity, salty, acidic or basic) atmospheres.



If the engine support bracket is defective, it must be taken out of service immediately.



It may only be used to lift Volkswagen AG-approved Base Minus engines.

2.4 Basic principles for working with the engine support bracket



Risk of injury

The engine support bracket must be positioned so that there is no danger of crushing.



Load-carrying capacity

Before using the engine support bracket, check that the specified rated load of 70 kg (220.5 lbs) has not been exceeded.



Stable positioning

The lifting device may only be used on a horizontal, level, solid floor.



Warranty

The manufacturer accepts no liability for damage caused by improperly performed repairs.



Improper use of the device that causes damage to equipment will invalidate the warranty.



Only use the screws provided.

2.5 Regular inspection and maintenance



The inspection must only be carried out by qualified personnel. The engine support bracket must be inspected at least once a year. If the tool is used frequently, inspection must be performed at shorter intervals. The inspection mainly comprises visual and functional checks intended to assess the condition of the parts with regard to damage, wear, corrosion or other changes, as well as checks to assess the completeness and effectiveness of the safety precautions.



Repairs may only be performed by the manufacturer or by a person authorized by the manufacturer.



Surface damage must be repaired so as to prevent corrosion. The device must be cleaned every six months or as necessary if heavily soiled.

Inspections must be arranged by the operator.

3.1 Application

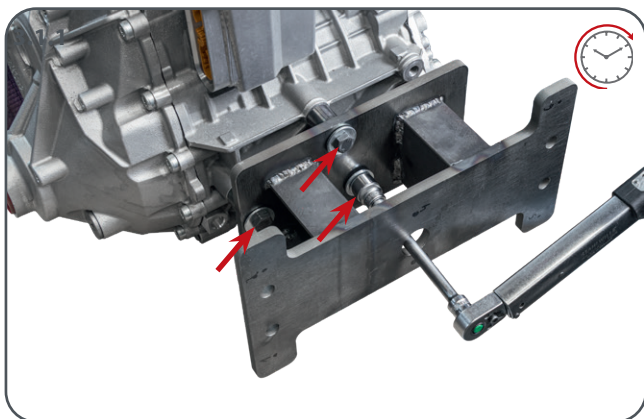

3.1.1

Fasten the VW 6095A/1-22 engine support bracket to the Base Minus engine using the three screws preinstalled on the engine support bracket. (Tightening torque 20 Nm)

3.1.2

Screw VW 309A and VAS 6095A/1-22 into place with the four supplied screws and washers M12x1.5x35 10.9. (Tightening torque 80 Nm)

3.1.3 / 3.1.4

Engine in secured state.

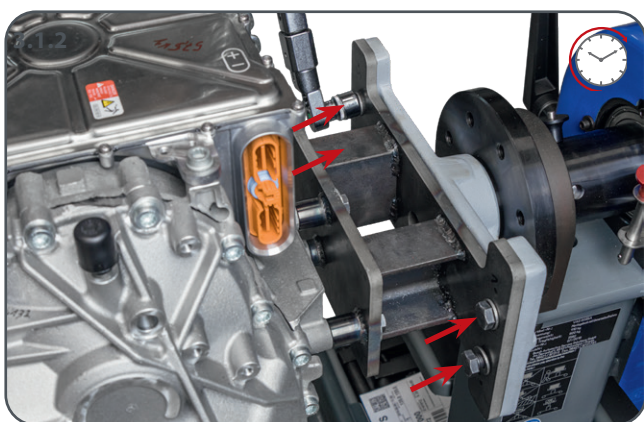

Take into account the permitted lifting weight of the jack.



CE-mark on the jack may expire.



The lifting device may only be moved when it is at its lowest position.



Removal and lifting of the engine according to VW specifications.



Pay attention to the lifting device and load during all movements.

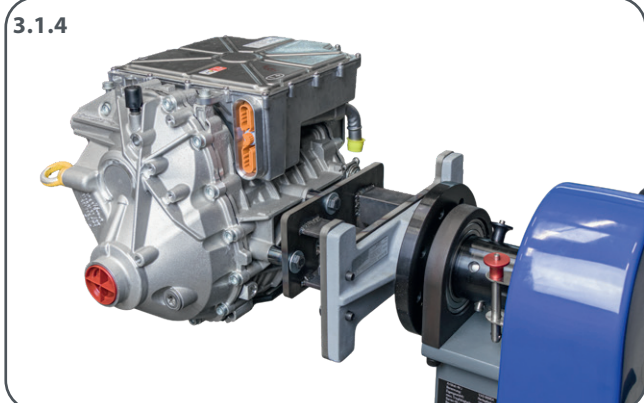
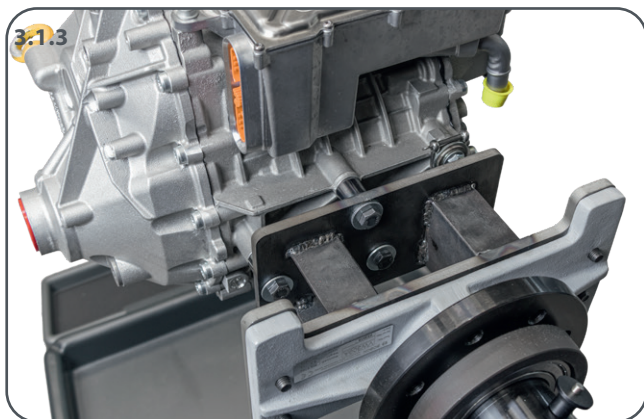

3.2 Completing the operation and storing the engine support bracket



3.2.1

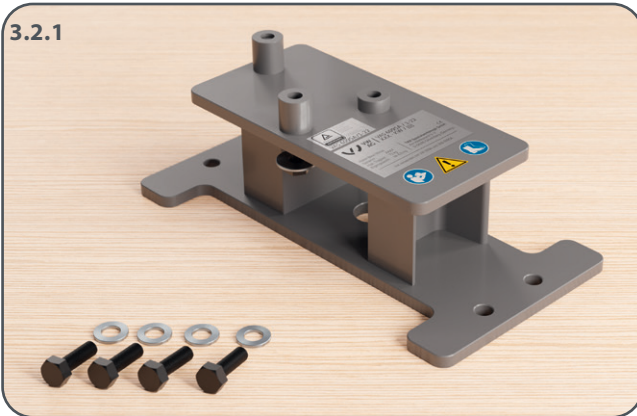

Before and after each operation, check the engine support bracket for any damage.

Store the engine support bracket as shown in the picture. The engine support bracket must be cleaned before storing it.

Always clean the tool before storing and store it in a safe place. Avoid contamination.

4.1 Troubleshooting

Malfunction	Problem	Remedy	Section
Support does not fit	Wrong engine	Check the engine identification marking	3.1
	Wrong support point selected	Check the support points	3.1
Screws do not fit	Wrong engine	Check the engine identification marking	3.1
	Wrong support point selected	Check the support points	3.1
Connecting screws on VW 309A do not fit	Did not use the supplied screws	Check the screws	3.1
	Thread dirty	Clean the thread	



4.2 Warranty

A 24-month warranty against defects in material or workmanship is provided for the engine support bracket of type designation VAS 6095 A / 1-22.

The warranty begins on the date of delivery, as specified on the invoice or delivery note.

The warranty is valid for the user / customer provided that the tool is obtained from an authorized sales outlet and is used as described in the instructions for its intended use.

The warranty becomes invalid if the tool is used for purposes other than the intended use.

In addition, the warranty becomes invalid if the tool is not used as described in the owner's manual.

In the event of defect or fault, TKR Spezialwerkzeuge GmbH will only repair or replace faulty parts at its own discretion.

Service address

TKR Spezialwerkzeuge GmbH

Service

Am Waldesrand 9-11

D-58285 Gevelsberg (Germany)

Phone +49 2332 66607-0

Fax +49 2332 66607-941

E-mail info@tkrgroup.com

4.3 Disposal



Machinery, equipment and their components must be disposed of as prescribed by the laws, regulations and other provisions of the country in which they are located.

We recommend using licensed specialist companies for disposal.

EC Declaration of Conformity

In accordance with EU Machinery Directive
2006/42/EC

Manufacturer: TKR Spezialwerkzeuge GmbH
Am Waldesrand 9-11
58285 Gevelsberg, Germany

**Person authorized to
compile the technical
documentation:** Thorsten Weyland

Designation: VAS 6095 A / 1-21,
VAS 6095 A / 1-22

Tool type: Engine support bracket

Has been developed and designed in accordance with
the standards and guidelines specified below by

**TKR Spezialwerkzeuge GmbH
Am Waldesrand 9-11
DE-58285 Gevelsberg (Germany)**

Standard: DIN EN ISO 12100; DIN EN 13155:2003+A2:2009
Serial number range: 000001 – 010000

EU Machinery Directive: 2006/42/EC
As manufacturer, we declare: The products marked accordingly fulfill the requirements
of the directive and standards listed.

Thorsten Weyland

Gevelsberg, October 11, 2019 Thorsten Weyland
Technical Director



Am Waldesrand 9-11
D-58285 Gevelsberg (Germany)

Phone +49 2332 66607-0
Fax +49 2332 66607-941
E-mail info@tkrgroup.com
Internet www.tkrgroup.com