

1 General Information

Product Name:	Suspension and Holding Fixture
Product Type:	Load holding device
Product Number:	T40406
Weight:	15 kg
Max. Load Capacity:	250 kg
Static Test Coefficient:	3.0

Intended Use:

- ▶ The suspension and holding fixture lifts and transports gearboxes specified in and in accordance with the workshop manuals of the Volkswagen Group brands.

Terms of Use:

- ▶ For qualified workshop personnel only.
- ▶ Use only for work approved by the Volkswagen Group.
- ▶ Use only for loads up to 250 kg.
- ▶ Use only with a workshop crane that has been approved by the Volkswagen Group (e.g. VAS 6100).
- ▶ Use only with a gearbox that has been approved by the Volkswagen Group and that has suitable attachment points.
- ▶ Do not hold or lift any people or animals.
- ▶ Do not hold or lift items other than those described in the workshop manuals of the Volkswagen Group brands.
- ▶ Do not work on suspended loads.
- ▶ Do not stand under suspended loads.
- ▶ Lift and lower loads only on level, even, and stable ground.
- ▶ Use only with the accessories that have been approved by the Volkswagen Group (see the Volkswagen Group brands workshop manuals).
- ▶ Do not work on suspended loads.
- ▶ Use only at ambient air temperatures between -20 °C and +80 °C.

Included in Delivery

Product Number:	Product Name:	Quantity:
T40406	Traverse with support bracket, rear	1
T40406/1	Front bracket	1
T40406/2	Front bracket, hybrid	1
T40406/3	Spindle, fixed to the support brackets	2 pieces per support bracket

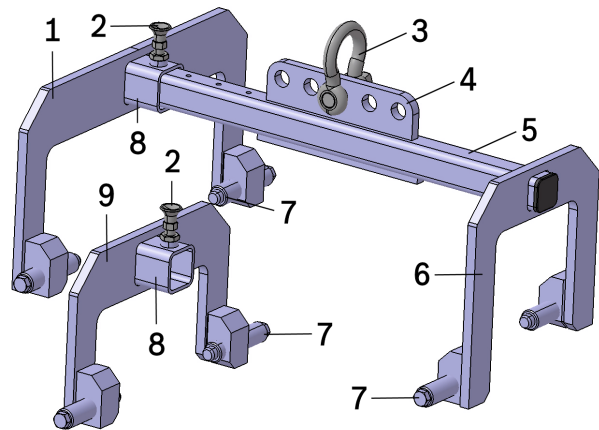

Figure 1: Suspension and holding device

- 1** T40406/2 Front bracket for hybrid
- 2** Locking pin
- 3** Shackle
- 4** Retainer
- 5** Traverse
- 6** Support bracket, rear
- 7** T40406/3 Spindle, 2 pieces per support bracket
- 8** Tube, 1 piece per front bracket
- 9** T40406/1 Front bracket

2 General Safety Instructions

WARNING

Read and follow all safety notes and instructions!

Failure to follow the safety instructions could result in serious injuries and severe damage to materials.

Observe and follow the safety notes below.

- ▶ The load holding device has been specifically constructed for its intended use. The safety of the load holding device can no longer be ensured if it is misused or modified in ways not expressly approved by the manufacturer. Serious personal injuries or severe damage to materials could occur.
- ▶ Ensure that each person using the load holding device is familiar with these instructions and can access them at all times.
- ▶ Ensure that all users are also familiar with the instructions of the additional tools and workshop equipment that are necessary for the work.
- ▶ Carefully read and adhere to the instructions in the technical safety information of the Volkswagen Group brands.
- ▶ Wear safety shoes (in accordance with ISO 20345, S2).
- ▶ Wear protective gloves in order to avoid cuts.
- ▶ Position hands and feet so as to avoid potential crushing hazards.
- ▶ Use and store only in dry environments without a corrosive atmosphere (e.g. acidic or caustic).
- ▶ Do not use in potentially explosive environments.
- ▶ Use the load holding device only for work approved by the Volkswagen Group.
- ▶ Use the load holding device only with the accessories approved by the Volkswagen Group.
- ▶ Do not exceed the maximum load capacity of 250 kg.
- ▶ Ensure that the path is clear and easily visible.
- ▶ Move the load slowly and smoothly.
- ▶ Observe the load holding device and the load during all movements.
- ▶ Do not use the load holding device to tear stuck loads loose or to drag loads on the floor.
- ▶ Keep clear of suspended loads at all times.
- ▶ Persons may not be under the load or in the hazard area while the load is being moved.
- ▶ Do not work on suspended loads.

3 Operating Instructions

1. Ensure that the suspension and holding device is complete and inspect it for visible damage such as signs of wear, deformation, breaks, cracks, and corrosion before each use. Do not use the suspension and holding device if damaged or in poor condition, but discard it immediately.

2. Perform the necessary preparatory work to use the suspension and holding fixture in accordance with the workshop manuals of the Volkswagen Group brands.

3. If necessary, exchange the front bracket (9) with the front bracket for hybrid (1) or the other way around.

Pull up on the locking pin (2) on the tube (8). Remove the front bracket (1) or (9) from the traverse (5).

Pull up on the locking pin (2) on the tube (8). Slide the tube (8) on the front bracket (1) or (9) onto the traverse (5). Release the locking pin (2) and let it lock into place in one of the holes in the traverse (5).

4. If necessary, slide the front bracket (1) or (9) on the traverse (5) so that both spindles (7) will fit in the attachment holes in the gearbox.

Pull up on the locking pin (2) on the tube (8). Slide the front bracket (1) or (9) to the desired position on the traverse (5). Release the locking pin (2) and let it lock into place in one of the holes in the traverse (5).

5. Align the traverse (5) to be parallel to the gearbox's central axis.

6. Attach the suspension and holding fixture to the gearbox in accordance with the workshop manuals of the Volkswagen Group brands.

Insert the spindles (7) in the holes in the gearbox that are specified in the workshop manuals of the Volkswagen Group brands. Tighten the spindles (7) by hand.

WARNING

Danger of a Falling Load!

Attaching the suspension and holding fixture to the gearbox incorrectly could cause the load to swing out or fall. This could cause serious personal injury or severe damage to materials.

- ▶ Attach the suspension and holding fixture to the gearbox exactly as described in the workshop manuals of the Volkswagen Group brands.
- ▶ Tighten the spindles by hand to attach the suspension and holding fixture to the gearbox.

7. If necessary, hang the shackle (3) from another hold in the retainer (4) so that the suspension and holding fixture and the gearbox will hang straight from the workshop crane (see Figure 2).

Secure that shackle (3) to the retainer (4) with the pin.

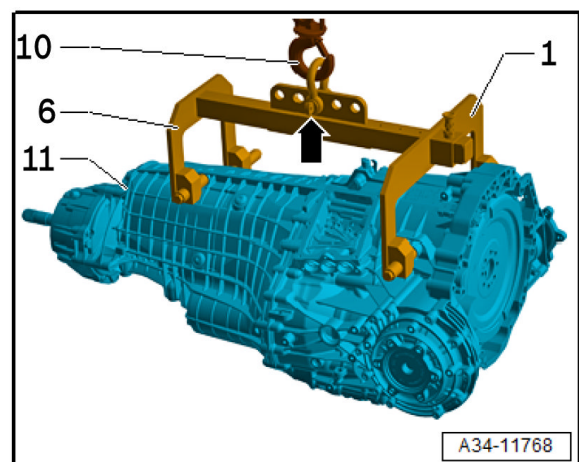

Figure 2: Suspension and holding fixture attached to the gearbox

- 1** T40406/2 Front bracket for hybrid
- 6** Support bracket, rear
- 10** Hook on the workshop crane
- 11** Gearbox

8. Hang the suspension and holding fixture on the workshop crane, e.g. VAS 6100, from the shackle (3). Close the hook on the workshop crane.
9. Carefully lift the gearbox and set it down at the operating site. Keep clear of the load when setting it down.

10. Perform further work as described in the workshop manuals.
11. Ensure that all parts of the special tool have been removed after completing the service and maintenance work.

NOTICE

The spindles could get stuck!

If the spindles get stuck while removing the suspension and holding fixture from the gearbox, loosen the spindles with a spanner.

- ▶ *Use a spanner only to loosen the suspension and holding fixture from the gearbox.*
- ▶ *Tighten the spindles by hand to attach the suspension and holding fixture to the gearbox.*

12. Store the suspension and holding fixture in a clean and dry location.

4 Inspection and Maintenance

Ensure that the suspension and holding device is complete and inspect it for visible damage such as signs of wear, deformation, breaks, cracks, and corrosion before each use. Do not use the suspension and holding device if damaged or in poor condition, but discard it immediately.

Replacement parts are available upon request. Use only original replacement parts.

Contact your first-level support representative with any queries.

NOTICE

Modifications to this product which have been expressly approved by the manufacturer will void any warranty. The manufacturer assumes no liability for personal injuries or damage to materials which occur as the result of improper use of the product.



Declaration of Conformity with the Machinery Directive 2006/42/EC, Annex II 1A

Manufacturer:	Bosch Automotive Service Solutions GmbH Am Dörrenhof 1 85131 Pollenfeld-Preith Germany
Authorized to compile the technical documents:	Bosch Automotive Service Solutions GmbH Am Dörrenhof 1 85131 Pollenfeld-Preith Germany
Product Name:	Suspension and Holding Fixture
Product Type:	Load holding device
Product Number:	T40406

We hereby declare that the product described above complies with the relevant clauses of the 2006/42/EC Machinery Directive.

Any modification to the product not expressly approved by the manufacturer will void the validity of this declaration.

The following harmonized standards have been applied:

EN ISO 12100:2010	Safety of machinery — General principles for design — Risk assessment and risk reduction
EN 13155:2003+A2:2009	Cranes — Safety — Non-fixed load lifting attachments

Pollenfeld, 2019-12-06

Place, Date

Carsten Henkel, Managing Director