

EVAPORATIVE EMISSIONS TESTER

KLI9210DLX **OPERATION** **MANUAL**

Table of Contents

GENERAL INFORMATION.....	1
UNPACKING & SETUP	2
Included Accessories.....	2
CHECK LIST	4
SELF-TEST INSTRUCTIONS	4
CALIBRATING & TESTING FOR LEAK STANDARD (.020" - .040").....	5
TESTING AT VEHICLE TEST PORT.....	6
TESTING AT FUEL FILLER NECK	7
TESTING AT FUEL CAP	8
TESTING ENGINE W/O TEST PORT	8
TESTING WITH VEHICLE CAP HOSE ASSEMBLY	9
LOCATING LEAKS USING SMOKE GENERATION UNIT	10
LOCATING LEAKS USING ULTRASONIC LEAK DETECTOR.....	11
TROUBLESHOOTING TIPS	12
USING ACCESSORIES	13
AVAILABLE ACCESSORIES	14
REPLACEMENT PARTS REFERENCE	15
WARRANTY.....	16
ALL RETURNS	16

View: As Assembled from Factory

Two simple procedures are required to fully assemble Tester:

1. Install Tester's flow meter onto control panel.
2. Mount Nitrogen tank onto cart (nitrogen tank not supplied). Install supplied high pressure regulator onto Nitrogen tank.

NOTE: See pages 2 & 3 for detailed assembly instructions.

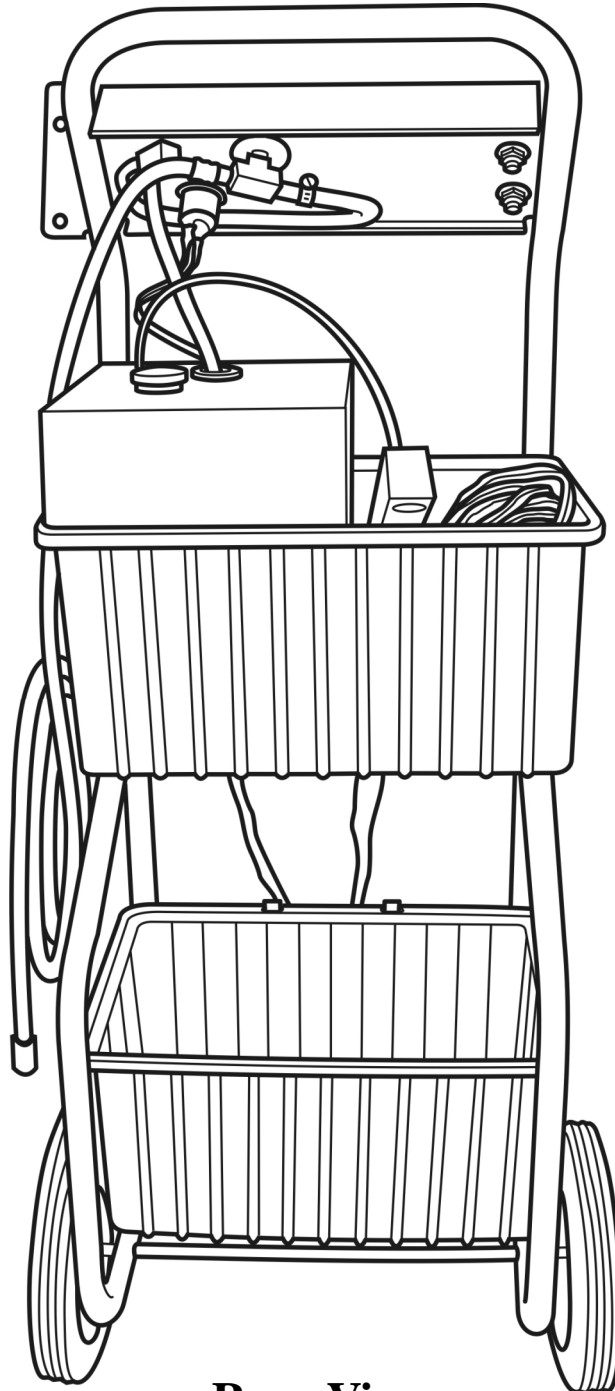

Rear View

View: Fully Assembled

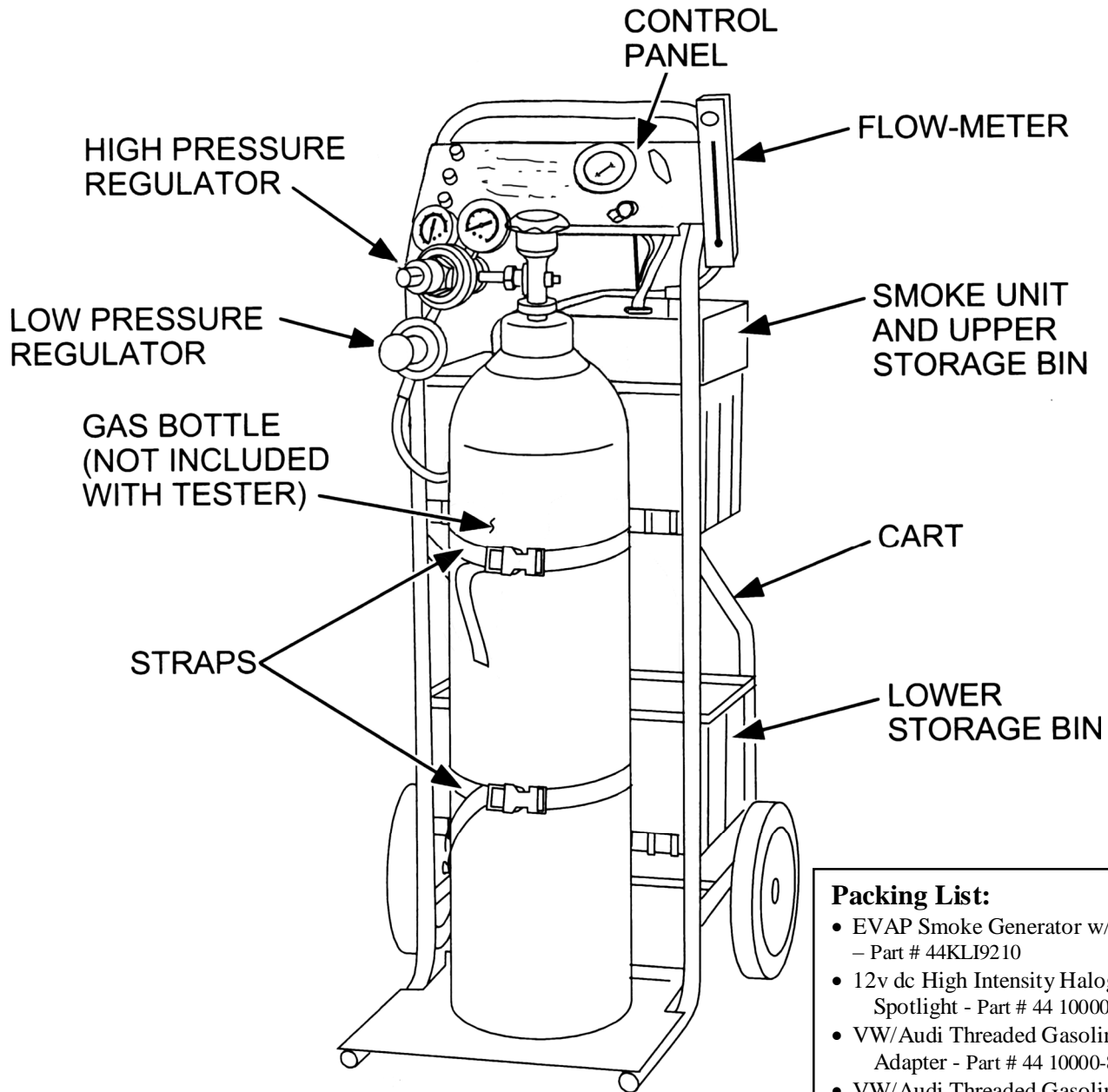

Front View

KLI9210DLX

- Packing List:**
- EVAP Smoke Generator w/ cart
- Part # 44KLI9210
 - 12v dc High Intensity Halogen
Spotlight - Part # 44 10000-100
 - VW/Audi Threaded Gasoline Cap
Adapter - Part # 44 10000-80
 - VW/Audi Threaded Gasoline Cap
Receiver - Part # 44 10000-81
 - VEHICLE/CAP TEST HOSE
- Part # 44 10000-82
 - Ultra sonic Leak Detector
- Part # 443633
 - Extension Tube
- Part # 443632-7
 - Earphones
- Part # 453633A

View: Control Panel

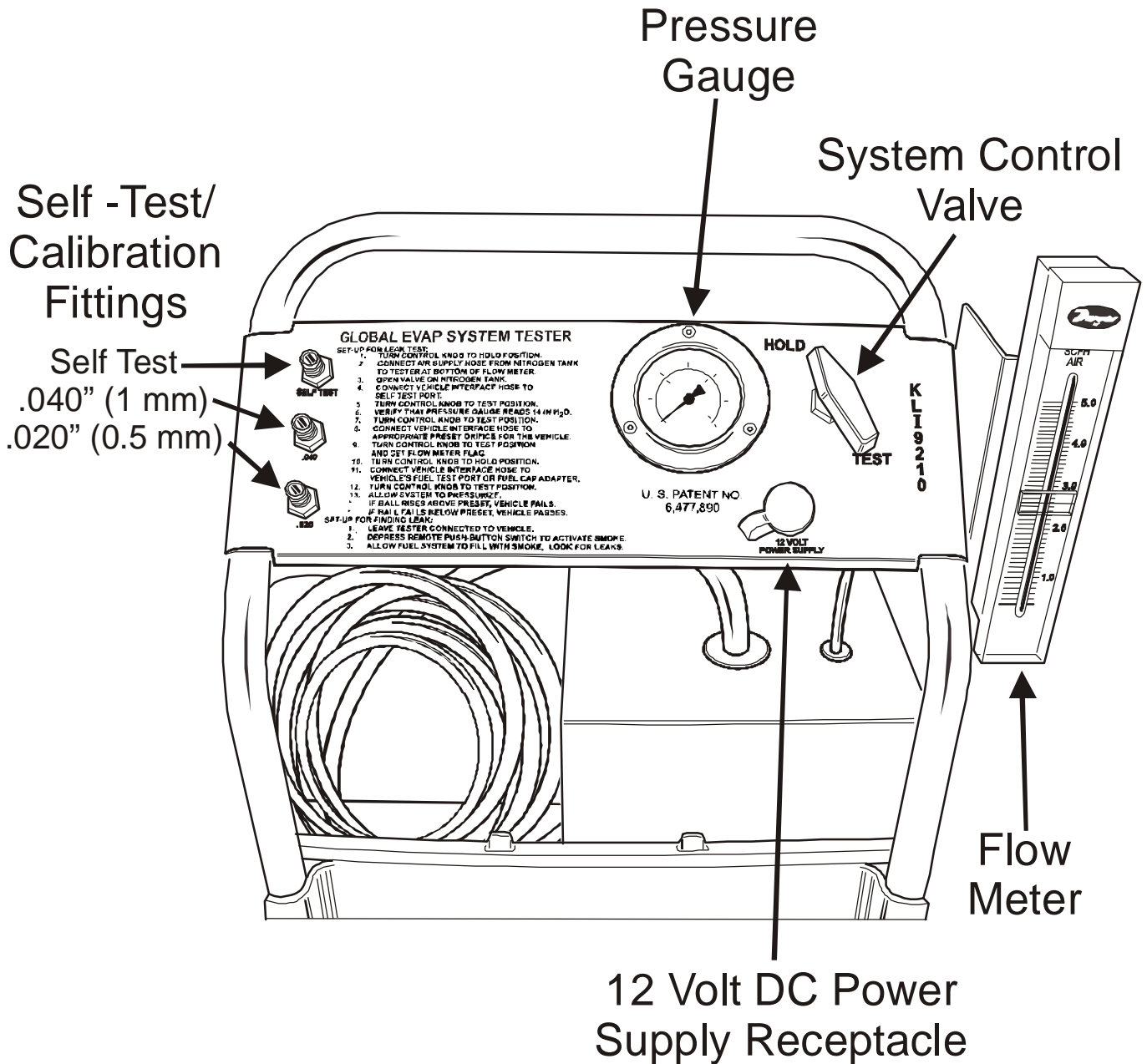

GENERAL INFORMATION

The KLI9210 Evaporative Emission System Tester is designed to test for emission leaks in the fuel and evaporative emissions systems of vehicles equipped with OBDII on-board diagnostics. If a leak is detected in the fuel or evaporative emissions systems (refer to the vehicles manufacturer's service manual for fault code information), the tester will pressure check the system for easy leak detection and location. With the system properly pressurized by the KLI9210 test unit, leak size (by the use of the flow meter) and location (by the use of the Smoke Generation Unit and/or the use of other accessories) can be determined and repaired.

The KLI9210 comes with all the equipment necessary to properly diagnose the system, except for the nitrogen gas cylinder needed to pressurize systems during the test process. Nitrogen gas cylinders are available from your local gas suppliers. We recommend the common industrial size tank, reference: D or S tank.

The KLI9210 Evaporative Emissions System Tester w/Smoke Generation Unit can, with the purchase of additional accessories, also find leaks in the following systems. See page 14 for list of accessories.

1. Manifold system leaks
2. Exhaust system leaks
3. Under-dash vacuum system leaks
4. Turbo charger leaks
5. Wind and water leaks in the passenger compartment

CAUTION!!!

IMPORTANT!!!

Read Before Operating Unit!!!

NEVER attach the KLI9210 to any combustible gas!

Use ONLY Nitrogen gas cylinders that are properly maintained and in good working order. The KLI9210 is supplied with a specific regulator (pipe thread: 960-14 NGO, an industrial standard) for pressure control designed for use only with nitrogen gas cylinder tanks. Unit must be used only according to these instructions; failure to follow these instructions may lead to personal injury and property damage.

NEVER depress the remote smoke trigger before first turning 'ON' the nitrogen supply to the tester!

UNPACKING & SETUP

The KLI9210 Evaporative Emissions System Tester ships with all the necessary adapters, Flow Meter, regulators and the Smoke Generation Unit plus any additional accessories that were ordered with the unit.

1. Remove all items from the shipping boxes. You should find the following:

Included Items:

- EVAP Smoke Generator with cart – Part # 44KLI9210
- 12v dc High Intensity Halogen Spotlight - Part # 44 10000-100
- VW/Audi Threaded Gasoline Cap Adapter - Part # 44 10000-80
- VW/Audi Threaded Gasoline Cap Receiver - Part # 44 10000-81
- VEHICLE/CAP TEST HOSE - Part # 44 10000-82
- Ultra sonic Leak Detector - Part # 443633
- Extension Tube - Part # 443632-7
- Earphones - Part # 453633A

See page 14 for additional accessories.

2. Tester arrives almost fully assembled. Store any adapters, light and other accessories included with the Tester in lower storage bin (fig. 1).
3. Make sure that the slots on both storage bins are seated on the cart brackets provided. The entire edge of the plastic bin should fit over the hanging bracket with the 2 tabs sticking through the holes in each bin. (fig. 2).

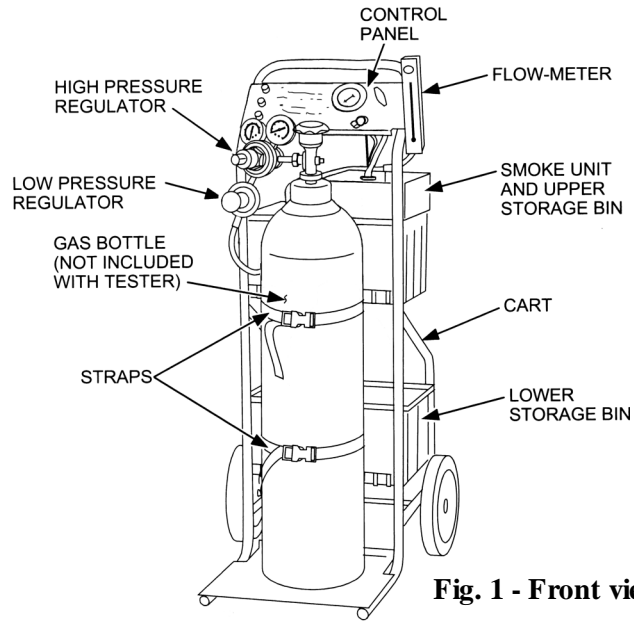

Fig. 1 - Front view

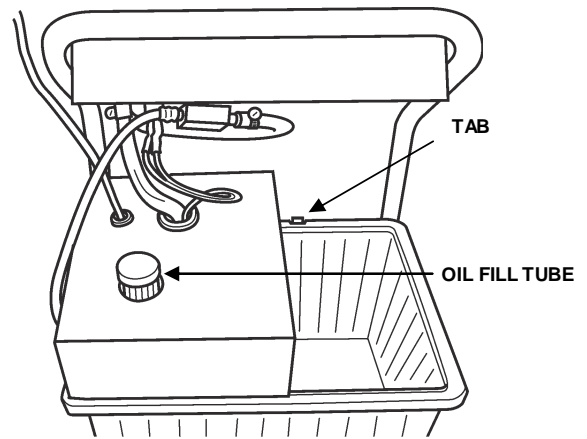

Fig. 2 Back view

IMPORTANT INFORMATION:

Read Before Operating Unit!

The smoke generation unit supplied with the KLI9210 is fully tested at the factory, drained and shipped without fluid in unit. Prior to use, the smoke generation unit must be filled with smoke generation fluid supplied with unit. Completely drain the fluid container into the smoke generation unit filler neck and dispose of the container according to your local/state requirements.

It's important to check the solution level and top off to the "Full" mark on the dipstick regularly, just as you would regularly check the oil level of a car's engine."

- cont'd

4. Locate the Flow Meter assembly and mount it on the right side of cart; making sure Meter is facing the front of cart (the side the Gas Cylinder bottle is located). Mounting is done by simply removing the two screws from the back of the flow meter and attaching it to the bracket (fig. 3) by replacing the screws through the two holes in the bracket. Do NOT over-tighten!

Fig. 3

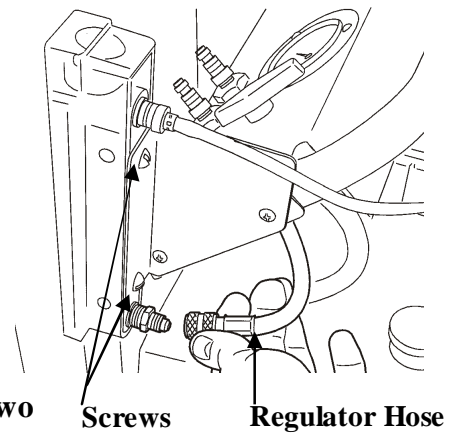

5. Locate the Regulator Assembly and connect it to the Nitrogen Gas Cylinder (fig. 4) (Gas Cylinder Not Supplied).

ⓘ IMPORTANT SAFETY POINT: Make sure the Gas Cylinder is securely fastened to the cart, with the two fastening straps provided, at all times (fig. 1).

6. Connect the black hose from the Regulator Assembly to the bottom port on the Flow Meter (fig 3). Tighten with wrench but DO NOT OVER-TIGHTEN!!!

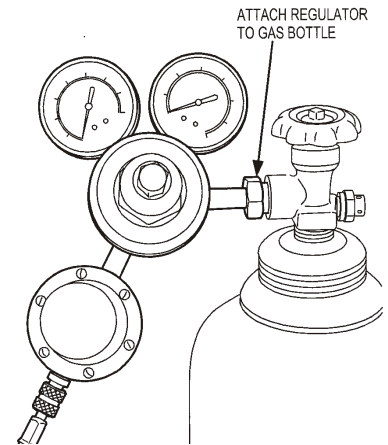

Fig. 4

This completes the unpacking and set-up instructions. If you have any questions regarding proper unpacking or set-up contact Global Leak Detection, Corp customer service at 1-877-669-2841 and request clarification.

IMPORTANT INFORMATION:

Read Before Operating Unit!

This unit requires a nitrogen gas cylinder [not supplied with unit] be attached to it in order to function correctly. The gas used MUST be nitrogen gas. Mount the bottle to the front of the EVAP cart and strap it in with the supplied retainer straps. Connect the supplied regulator to the bottled gas container and tighten. **IMPORTANT: DO NOT OVER TIGHTEN!!!**

CHECK LIST

1. Be sure that both vehicle being tested and the KLI9210 are at room temperature. These tests are based on 14 inches of water, or less than ½ PSI. Any variation can cause false readings.
2. When the KLI9210 is not in use **ALWAYS** move the Control Valve to the **HOLD** position and turn the Gas Cylinder Valve **OFF**. This will prevent loss of nitrogen gas due to valve being left open or a vehicle component not working correctly.
- 3 Follow all procedures in “Vehicle Manufacturer’s Service Manual.” On some vehicles, valves and/or hoses may need to be shut or closed off.

ⓘ IMPORTANT SAFETY POINT:

Always disconnect 12 Volt power connectors from power source when not in use.

IMPORTANT INFORMATION:

The vehicle’s fuel tank should be between ¼ and ¾ full for performing tests. Having the fuel tank over ¾ full could cause fuel to back up into tester when the system is pressurized.

SELF-TEST INSTRUCTIONS

ⓘ IMPORTANT SAFETY POINT:

Make sure the Nitrogen Tank is properly hooked up and positioned at all times.

1. Make sure the control valve on the panel is in the **HOLD** position and open the nitrogen bottle.
2. Connect Vehicle Interface Hose to the Self-Test Port (fig. 5) located on the Control Panel. Hand-tighten the fitting; **DO NOT OVER-TIGHTEN!!!**
3. Turn Control Valve to **TEST** position (fig. 6).
4. Gauge should read 14 inches of water, plus or minus 1 inch. (This is pre-set at the factory. If gauge is not reading in this range, please adjust the pressure by turning the black knob on the Low Pressure Regulator at the tank until the gauge reads 14 inches of water.)
5. Turn Control Valve to “**HOLD**” position.
6. Note whether the gauge holds pressure and check that the Flow Meter reads **NO** flow. (If the gauge leaks down, confirm that the vehicle interface hose is connected firmly and re-test. If gauge leaks down again, try to determine cause of leak. Otherwise contact Global Leak Detection customer service/technical support at 1-877-669-2841 for instructions.)
7. No drop in pressure or flow — unit passed self-test.

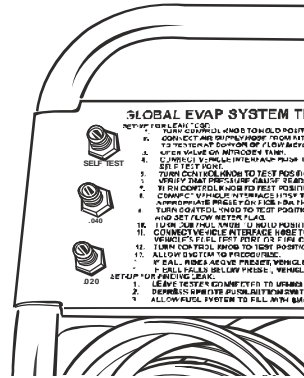

Fig. 5

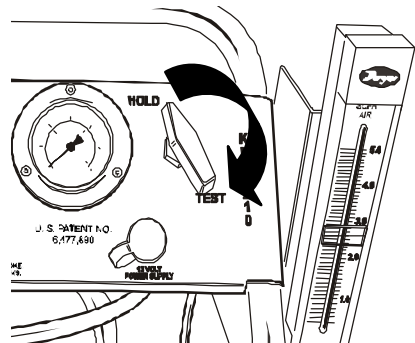

Fig. 6

CALIBRATING & TESTING FOR LEAK STANDARD (.020" - .040")

When calibrating unit you will need to determine what standard to test to. Please refer to Vehicle Manufacturer's Service Manual for this information.

1. Complete the Self-Test, on previous page, to assure the machine is set-up properly.
2. Make sure the Control Valve is in the HOLD position and that the valve on the cylinder of nitrogen gas is open.
3. Find the Preset test orifice on the front of the KLI9210 that reflects the standard (.020" or .040") you are testing to (fig. 7). Connect the KL19210 vehicle interface hose to the preset and turn the control valve to the TEST position.
4. Mark the Flow Meter reading with the pointer flag (fig. 8) (.020" should read in the lower range of the Flow Meter and the .040" should read in the higher range of the Flow Meter).
5. Run either test on the vehicle or fuel cap as described in the instructions for each test procedure that follows this section.
6. Compare the flow reading, while the system is connected to the vehicle with the system pressurized to the pointer, for the leak size specification for the vehicle.
7. If the flow ball reading is above the calibrated flow marker (fig. 8), then the vehicle failed the test and a repair is required. If the flow reading is below the calibrated flow market, then vehicle passed the test and no further action is required.
8. Turn the control valve to the HOLD position.
9. Refer to "Locating Leaks Using Smoke Generation Unit" – page 10 & "Locating Leaks Using Ultrasonic Leak Detector" – page 11 for further instructions.

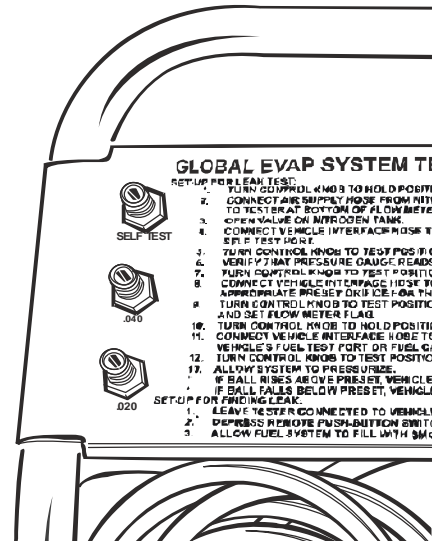

Fig. 7

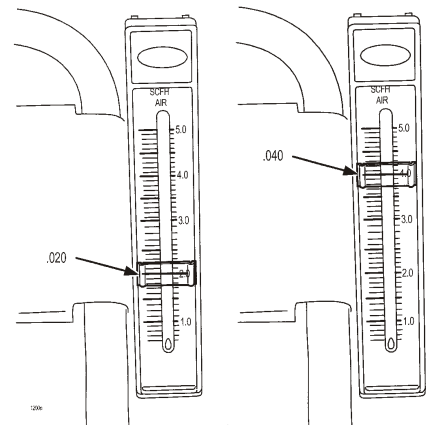

Fig. 8

Testing at Vehicle Test Port

1. Make sure the control valve is in the HOLD position and that the valve on the nitrogen gas cylinder is turned to open.

2. After completing Self-Test Instructions, locate Vehicle's EVAP Test Port Fitting Cap (fig. 9) and unthread it. Connect the KLI9210's Vehicle Interface Hose directly to the test port fitting (fig. 10) (This fitting is normally located under the hood of the vehicle and towards the fire wall. It can be located on either side of the vehicle. In most, if not all, cases the cap on the EVAP Test Port Fitting is green in color). **HAND-TIGHTEN ONLY!!**

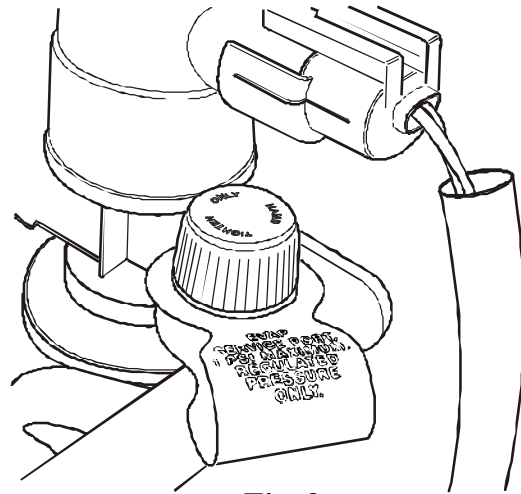

Fig. 9

a) Make sure to take all necessary steps to isolate the fuel system/EVAP system from the canister purge valve/release valve, etc.

Note: Prior to step #2 above, you may remove service port Schrader valve to improve smoke vapor performance. Schrader valve is Left-Hand thread!

3. Turn control valve to open position and let the system fill. You should note lower than 14 inches on the pressure gauge along with the flow meter ball being pegged for several minutes, depending on the size of the tank and the amount of fuel in the system. This is normal.

4. If after several minutes the gauge and the flow meter ball does not settle to a measurable level, then refer to Vehicle Manufacturer's Service Manual to ensure everything is shut off and the system is properly isolated.

5. If there are no leaks in the system you will see "zero flow" on the flow meter and the pressure gauge should return to the preset pressure of 14 inches of H₂O. If you do measure the flow and the pressure does not return to the preset level of 14 inches of H₂O then you have determined that there is a leak in the vehicle's evaporative emissions system. Please proceed to "Testing for the Leak Standard (.020" - .040")" – page 5.

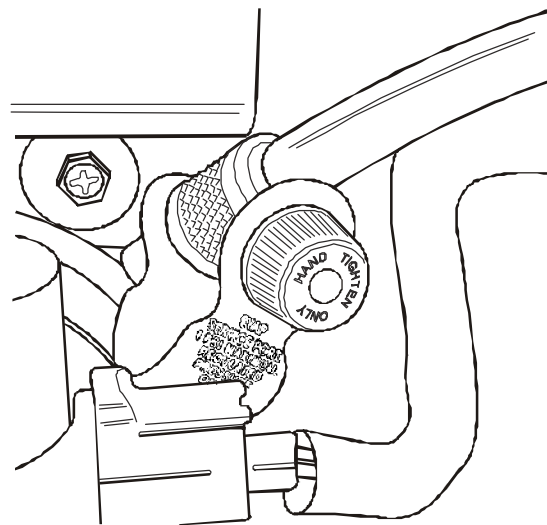

Fig. 10

6. If the flow reading is higher than the pointer flag (see page 5, fig. 8), then the vehicle failed the test and a repair must be completed on vehicle. If the flow reading is less than the flag, then the vehicle passed the test and no further action is required.

7. Turn the control valve to the HOLD position.

TESTING AT FUEL FILLER NECK

1. After completing Self-Test Instructions, open the fuel door on the vehicle and remove fuel cap. Install the appropriate Fuel Cap Adapter as illustrated below (fig. 11) into the vehicle's Fuel Filler Neck.

a) Make sure that all necessary steps are taken to isolate the fuel system/EVAP system from the canister purge valve/release

2. Make sure the control valve is in the HOLD position. Now connect the KLI9210's Vehicle Interface Hose directly to the fuel cap adapter (fig. 11).

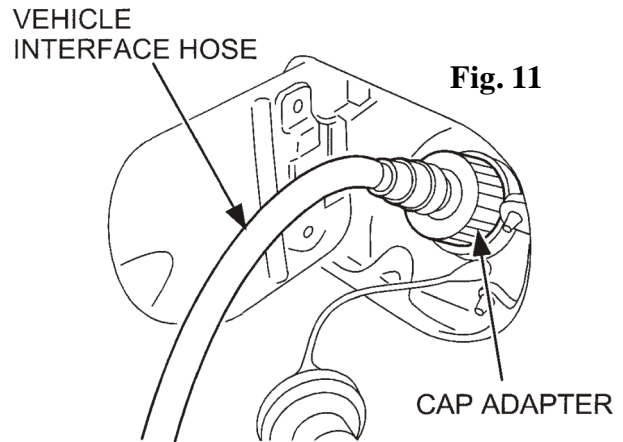

3. First, turn nitrogen gas cylinder

Control Valve to Open and then tester's control valve to TEST and let the system fill. You should note a level of lower than 14 inches on the pressure gauge along with the Flow Meter ball being pegged for several minutes, depending on the size of the tank and the amount of fuel in the system. This is normal.

4. If after several minutes the gauge and the Flow Meter ball does not settle to a measurable level, refer to Vehicle Manufacturer's Service Manual to insure that everything is shut off and the system is properly isolated.

5. If there are no leaks in the system, you will see "zero flow" on the Flow Meter and the pressure gauge will return to 14 inches of H₂O. If you do see the Meter Ball above the calibration setting, as outlined on page 5 and the pressure does not return to the preset level of 14 inches of H₂O, you have determined there is a leak in the vehicle's evaporative emissions system. (Please refer to page 5 for details on Testing to the Leak Standard)

6. If the flow meter ball is higher than the pointer flag (see page 5, fig. 8), then the vehicle failed the test and a repair must be completed on this vehicle. If the flow reading is less than the tell tale flag, then vehicle passed test and no further action is required.

7. Turn the control valve to the HOLD position.

TESTING AT FUEL CAP

1. Make sure the Control Valve is in the hold position and the valve on the nitrogen tank is turned open.
2. Remove fuel cap from vehicle.
3. Connect the appropriate Fuel Cap Receiver to the Vehicle Interface Hose.

IMPORTANT:

HAND-TIGHTEN ONLY!!

4. Turn fuel cap into fuel cap receiver (fig. 12) and tighten per cap instructions.
5. Turn the Control Valve to the TEST position

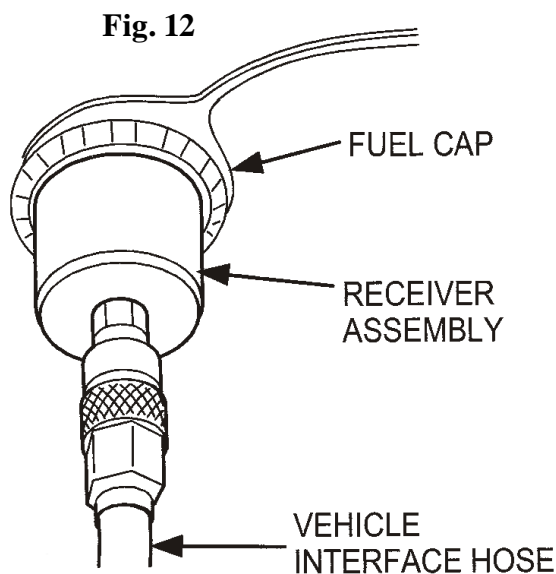

6. If the cap leaks, you will see the ball in the Flow Meter rise above the calibration setting. (see “Testing for the Leak Standard” – page 5 for more information)
7. If the meter flow reading is higher than the pointer flag (see page 5, fig. 8), then vehicle failed the test and a repair must be completed. If the flow reading is less than the flag settling, then the vehicle passed the test and no further action is required.
8. You can also turn Tester’s Control Valve to TEST to test for pressure drop, indicating a leak. However, pressure drop (decay) cannot determine leak size.

TESTING ENGINE W/O TEST PORT

Testing vehicles near the engine when the vehicle does not have a test port can be done using the threaded nozzle adapter (part # 4410000-102) (see accessories on page 14). This is included with the Additional Test Kit (part # 4510000-AD).

1. Disconnect the hose from the vehicle’s EVAP Purge Valve, that leads to the EVAP canister and insert the nozzle into the hose.
2. Perform the tests per instructions in “Testing at Vehicle Test Port” – page 6.

TESTING WITH VEHICLE/CAP TEST HOSE ASSEMBLY

This test utilizes Vehicle/Cap Test Hose p/n 4410000-82 (see accessories list on page 14).

1. Connect Vehicle/Cap Test Hose to appropriate Fuel Cap Receiver and Fuel Cap Adapter.
2. Remove the vehicle's fuel cap and thread it into the Fuel Cap Receiver.
3. Thread Fuel Cap Adapter into vehicle's Filler Neck.
4. Connect Tester's Vehicle Interface Hose to center fitting of Vehicle/Cap Test Hose (fig. 13).

You are now ready to test the Evaporative Emissions System with the vehicle's Fuel Cap in-line. Refer to "Testing at Fuel Filler Neck"- page 7, to complete test.

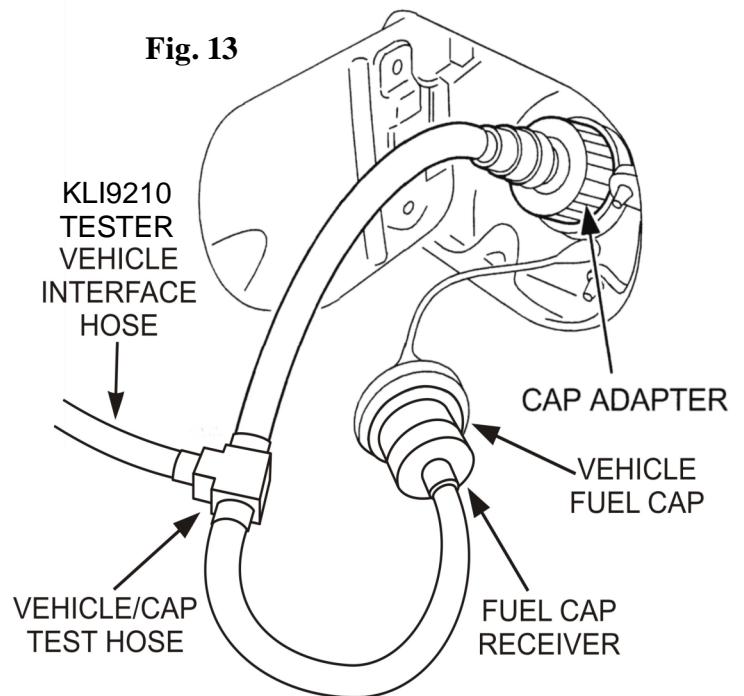

LOCATING LEAKS USING SMOKE GENERATION UNIT

1. With the KLI9210 still connected to the vehicle, first Open the valve on the Nitrogen tank, and then turn the Tester's Control Valve to the TEST position. Then connect the 12 volt power connector leads on the Smoke Generation Unit to the vehicle's battery. Make sure to connect Red lead to the positive post (+) or power and Black lead to vehicle's chassis ground.
 - a) You will probably want to raise the vehicle on a lift, to improve access for locating the leak.

CAUTION: make sure the hoses and cords are free while lifting the vehicle.

NEVER depress the remote smoke trigger before first opening the nitrogen tank valve and setting Tester Control Valve to TEST!

2. Depress the remote smoke trigger and allow system to fill with smoke.
3. If filling at the test port, you can remove the vehicle's fuel cap. This will allow for quicker filling of the system with smoke. NOTE: You must replace the fuel cap once you see smoke coming from the fuel filler neck. If your system is equipped with a 12 volt 400,000 candle power spot light (part # 4410000-100), this should be used to help locate the smoke. This can be plugged into the 12 volt power receptacle on the front of the Tester's control panel.
4. Note the location of the smoke and proceed with leak repair.
5. Re-test to confirm repair. If you do not locate smoke after looking over the vehicle completely for several minutes, once the system is fully filled with smoke, you may try to locate the leak using the ultrasonic leak detector; see next section "Locating Leaks Using Ultrasonic Leak Detector" - page 11, for instructions.

NOTE: The method outlined in the next section is best used for smaller leaks or multiple small leaks.

IMPORTANT NOTE:

Never run the smoke unit until you have determined that a leak exists in the vehicle's EVAP system. Flow originating from a leak is required to carry smoke to and through the leak.

LOCATING LEAKS USING ULTRASONIC LEAK DETECTOR

1. With the KLI9210 still connected to the vehicle and the Control Valve turned to the Test position, activate the Ultrasonic Leak Detector and put on the Headset. (fig. 14)
2. Depress the button on the Ultrasonic Leak Detector and hold down. Adjust the gain control as necessary to remove as much background noise as possible.
3. Trace the fuel system/EVAP system and listen for the ultrasonic sound that is produced when air escapes from the system.
4. NOTE: The smaller the leak, the greater the sound level will be. Use the Ultrasonic Leak Detector in coordination with the Smoke Generation Unit for complete leak detection capabilities.
5. Note the location of the sound, mark and repair the leak.
6. Re-Test to confirm repair.

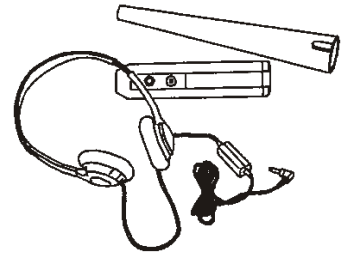

Fig. 14

TROUBLESHOOTING TIPS

PROBLEM:

THE ULTRASONIC LEAK DETECTOR WILL NOT TURN ON:

- a) Make sure the battery and connections to it are good.
- b) Make sure the battery is oriented properly. The positive and negative poles must match up to the positive and negative poles on the inside of the battery enclosure.
- c) Make sure the switch is working properly. If the switch doesn't have a slight spring action when pressed, then the tester must be returned to the factory for repair. See warranty section for more information.

PROBLEM:

IT IS TAKING AN EXCESSIVE AMOUNT OF TIME TO FILL A FUEL SYSTEM WITH NITROGEN GAS:

- a) Check the high pressure regulator gauge. If the pressure in the nitrogen gas cylinder is less than 500 psi, you should replace the cylinder. Make sure that the valve on the gas cylinder going to the regulator is shut off prior to removal. Make sure the new gas cylinder is securely attached to the cart prior to opening the valve.
- b) Check to make sure the EVAP system has been isolated and that the nitrogen gas is not escaping out the EVAP vent valve.
- c) Make sure there is nothing blocking the line to the test port adapter or the fuel cap test adapter. Check for kinks or holes in the lines connecting to the manifold assembly or the tester connections. Removing the EVAP Service Port Schrader valve will improve flow rate. NOTE: the Schrader valve is installed with left-hand thread.
- d) Try a different inert gas cylinder. Sometimes the valve can go bad on the cylinder and lead to a reduction in flow.
- e) Do a self-test on the EVAP unit itself to determine if there is a leak in the unit.

For additional trouble shooting assistance please contact Global Leak Detection, Corp technical service at 1-877-669-2841 between 8 am and 5pm, Pacific Time.

USING ACCESSORIES

ULTRASONIC TRANSMITTER W/DETECTOR

1. Place the Ultrasonic Transmitter (part # 453634) inside of the area where the leak is suspected and turn it on (i.e. passenger compartment or trunk).
2. Search for ultrasonic signal with detector (part # 443633).
3. When leak is found, repair and retest.

Example of Use: Excellent for finding wind noise leaks in window and door frames.

SMOKE DIFFUSER

The Smoke Diffuser – part # 4410000-121 (included in the EVAP Additional Test Kit – part # 4510000-AD) can be used when you need a more dense cloud of smoke. The smoke diffuser slows the smoke and creates a thicker, slow moving cloud of smoke. This works well for locating driver compartment leaks around windows and other similar types of leaks. Turn vehicle's climate control blower on HIGH. Be sure it is not set to Recirculate. This creates positive pressure. The leak is identified when the smoke is blown away from the area being tested.

CAP PLUGS

The set of Cap Plugs - part# 4510000-106 (included in the EVAP Additional Test Kit - part# 4510000-AD) can be used for plugging off many different size hoses/openings when testing vacuum and other systems with the smoke.

EXHAUST CONES







To use the Exhaust Cones you will also need the Threaded Nozzle Adapter – part # 4410000-102. Note: two Exhaust Cones and the nozzle are included in the EVAP Additional Test Kit – part # 4510000-AD.

1. Insert the Exhaust Cone into the tailpipe; Insert small end first until rubber cone seals to tailpipe.
2. Insert nozzle into the hose on the exhaust cone.
3. Run the KLI9210 smoke unit and fill the system with smoke—look for leak.
Note: It is best to leak test the exhaust system when it is cold, in order to avoid sealing small leaks due to thermal expansion.
4. Find leak, fix and retest.

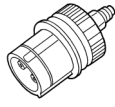
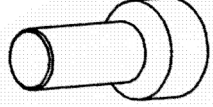
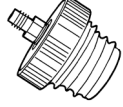
For dual exhaust you will need the 2nd cone and the smallest plug from the set of hose plugs – part # 4510000-106 (included in the EVAP Additional Test Kit – part # 4510000-AD)

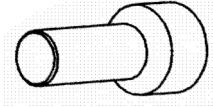
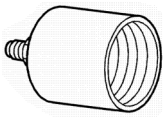
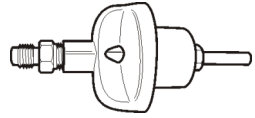
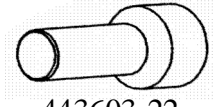
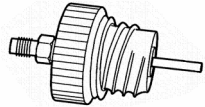
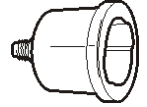
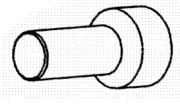
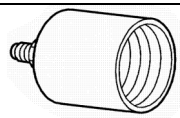
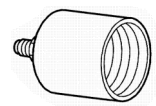
Directions: Insert 1 cone in each tailpipe and the plug in one hose and the smoke nozzle in the other and test as instructed above.

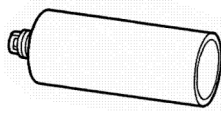
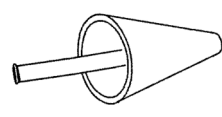
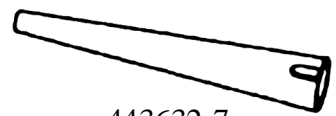
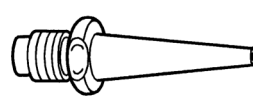
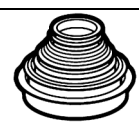
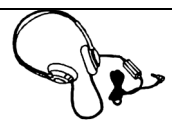
AVAILABLE ACCESSORIES

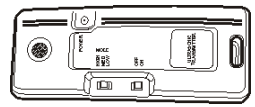
 <p>4410000-82 Vehicle/Cap Test Hose</p>	 <p>4410000-95 1/8 Turn Adapter</p>	 <p>443603-20 1/4 ID Plastic Plug</p>
 <p>44100000-80 EVAP Cap Adapter</p>	 <p>4410000-96 GM Receiver Assembly</p>	 <p>443603-21 5/16 ID Plastic Plug</p>
 <p>4410000-81 EVAP Receiver Assembly</p>	 <p>4410000-98 1/8 Turn Adapter Assbly</p>	 <p>443603-22 3/8 ID Plastic Plug</p>
 <p>4410000-93 Double Start Cap Adapter</p>	 <p>4410000-99 Receiver Assembly</p>	 <p>443603-23 3/16 ID Plastic Plug</p>
 <p>4410000-94 Cap Adapter Rcvr. Assbly</p>	 <p>453647Z-KM 2000 1/8 Turn Receiver</p>	 <p>443633 Ultrasonic Leak Detector</p>
 <p>4410000-121 Smoke Diffuser</p>	 <p>4410000-122 Exhaust Cone</p>	 <p>443632-7 Extension Tube</p>
 <p>4410000-102 Threaded Nozzle Adapter</p>	 <p>4510000-106 Cap Plug Set</p>	 <p>453633A Headset</p>
	 <p>4410000-100 Spotlight</p>	 <p>453634 Ultrasonic Transmitter</p>

REPLACEMENT PARTS REFERENCE

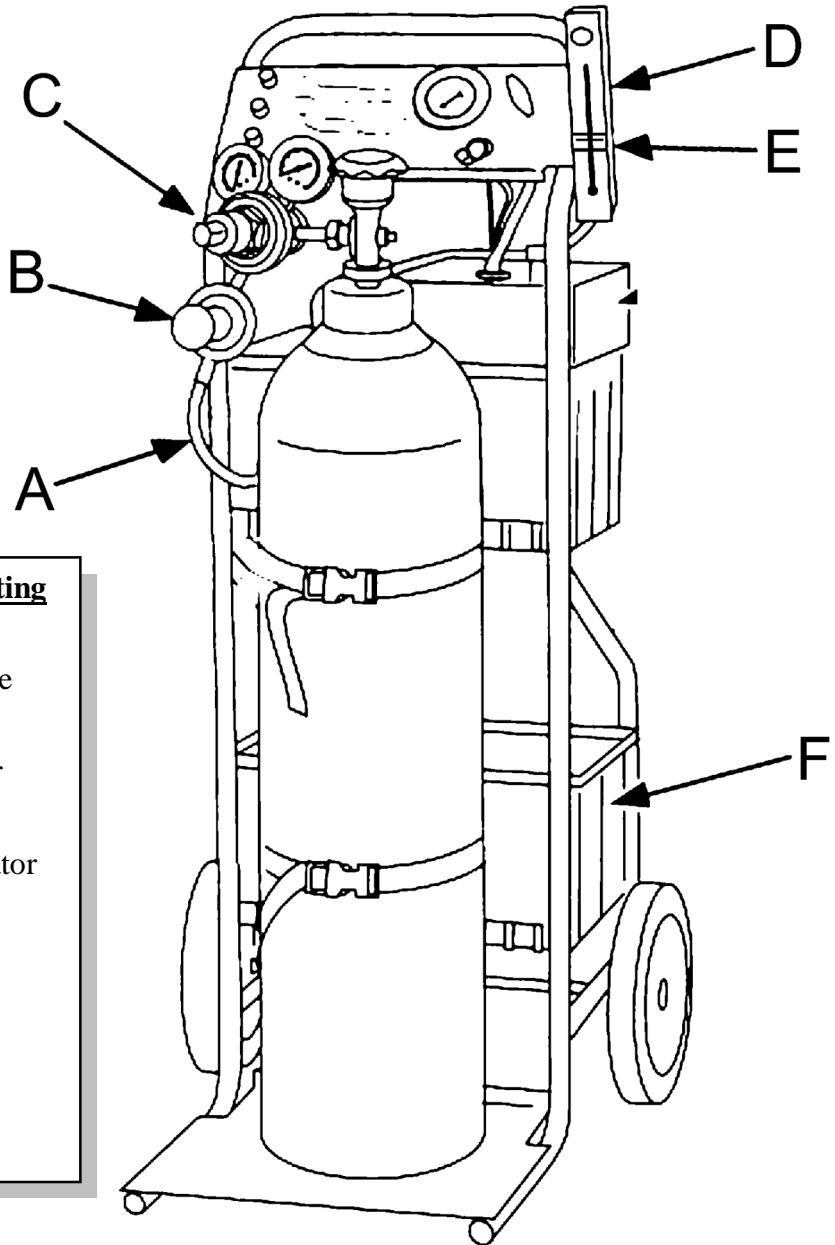

Replacement Parts Listing

- A - 4410000-88
Vehicle Interface Hose
- B - 443603-2
Fine Adjust Regulator
- C - 443649A
Cylinder Tank Regulator
- D - 4410000-12
Flow Meter
- E - 4410000-12
Flow Meter Flag
- F - 4410000-5
Storage Container

Parts Not Illustrated

- | | |
|------------|------------------------|
| 441000-200 | Instruction Manual |
| 4410000-55 | 25 Amp Fuse |
| 4410000-19 | 16 oz. Replacement Oil |

WARRANTY

For one (1) year on all parts, Global Leak Detection, Corp will replace or repair for the original purchaser, free of charge, any parts found upon examination by Global Leak Detection, Corp to be defective in material and/or workmanship. All transportation charges on parts submitted for repair or replacement under warranty will be paid by Global Leak Detection, Corp. If upon examination the part or parts are not covered by warranty, the person returning the part or parts will be charged for their repair or replacement as well as any prepaid shipping. The manufacturer shall in no event be liable to the purchaser for loss, damage, or injury to person or property of any kind or nature occasioned by or arising out of the operation, use, misuse, repair or replacement of this unit.

ALL RETURNS

All returns to MUST have a Return Product Authorization (RFA) number assigned prior to shipment of the return back to Global Leak Detection, Corp. Please contact customer service for an assigned RFA number.

Call Direct to Customer Service at 1-877-669-2841



www.gldcorp.com

Tech Support & Product Information

1-877-669-2841

Rev. 01-18-08